

Features

- Operates from single or dual power supply
- MH89726 extends transmission performance for the MT8972 (DNIC) at 160kbit/s line rate
- MH89728 extends transmission performance for the MT8972 (DNIC) at 80kbit/s line rate
- MH89726 and MH89728 are pin for pin compatible with each other
- Compact SIL package
- Over 6km loop range on 24 AWG

Applications

- Digital subscriber lines
- Digital PABX line cards and telephone sets
- High speed, limited distance modem
- ISDN U - Interface

ISSUE 2

November 1990

Ordering Information

MH89726/728 10 Pin SIL Package

0°C to 70°C

Description

The MH89728 and MH89726 are thick film hybrid devices which may be used to extend the operating range of the MT8972 (DNIC). The hybrids combine signal equalization and amplification for the receive and transmit paths on each device.

The small size of these hybrids makes them suitable for line card or terminal use with the MT8972. The gain of the transmit signal may be adjusted through the use of an external resistor.

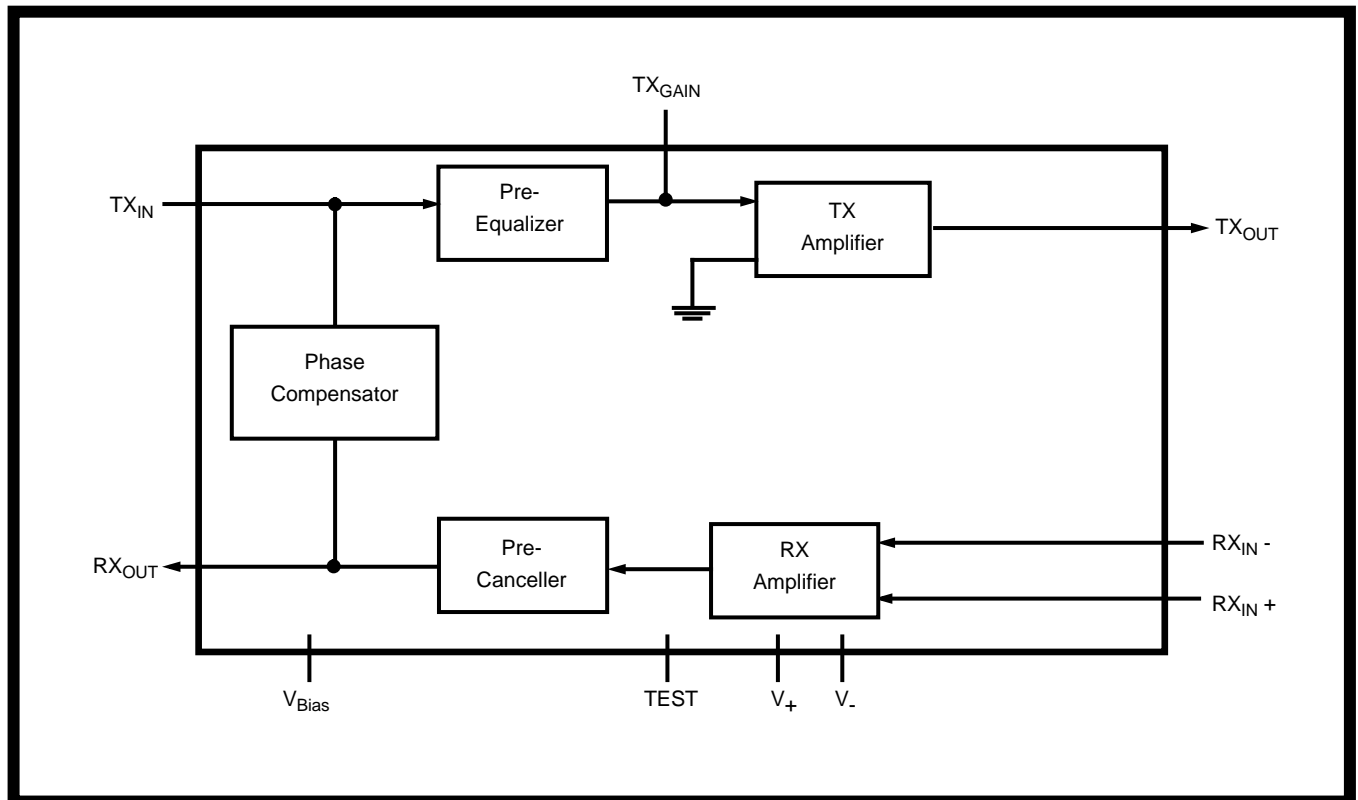

Figure 1 - Functional Block Diagram

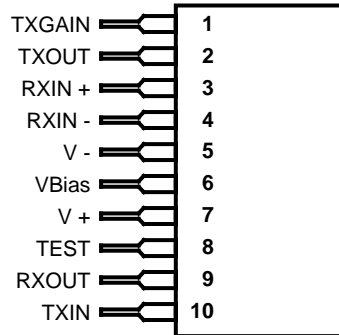

Figure 2 - Pin Connections

Pin Description

Pin #	Pin Name	Description
1	TX _{GAIN}	Transmit Gain. To be connected to Pin 2. An increase in gain can be achieved by connecting an external resistor R _{EXT} between Pin 1 and Pin 2. The resultant gain is calculated using; $A = (R/24) + 2.8$, where A=Gain and R= R _{EXT} (k Ω).
2	TX _{OUT}	Transmit Output. Connect to the termination network.
3	RX _{IN-}	Negative Receive Signal. Connect to TX _{OUT} , Pin 2.
4	RX _{IN+}	Positive Receive Signal. Connected to line transformer.
5	V-	Negative power supply.
6	V _{Bias}	Internal Bias Voltage. Connect to GND through 0.33 μ F for single power supplies. Connect to GND directly for split power supplies.
7	V+	Positive power supply.
8	TEST	Test. Used for production testing. Leave unconnected.
9	RX _{OUT}	Receive Output. Connect to L _{IN} (Pin 21) of MT8972.
10	TX _{IN}	Transmit Input. Connect to L _{OUT} (Pin 1) of MT8972.

Functional Description

The MH89726/728 are 10 pin SIL thick film hybrid circuits that may be used to extend the loop range capability of the MT8972 (DNIC). For a detailed description of the DNIC, refer to the MT8972 data sheet.

Figure 1 shows a block diagram of the Loop Extender Circuit (LEC). The LEC takes the line signal which is transmitted by the DNIC on L_{OUT}, pre-equalizes, and amplifies it before sending it to the termination network. The gain of the TX amplifier is adjustable by using an external resistor between pins 1 and 2. If no external resistor is added, TX_{GAIN} and TX_{OUT} must be shorted together, and the default gain condition exists. This gain results in a transmit signal power level of +10 dBm.

On the receive side, the LEC receives the differential line signal from the transformer, and performs first-order pre-cancellation as well as gain and phase adjustment of the receive signal. The signal is then output on RX_{OUT} which is connected to L_{IN} of the MT8972.

Tables 1 and 2 show typical results obtained by using the LEC with the MT8972. Actual distance achieved may vary depending on the characteristics of the transmission cable being used. Most important factors include cable attenuation (dB/km), bridged taps, and crosstalk interference.

The LEC is powered typically from ±15 Volts if dual power supplies are available. Alternately 0 to +30 Volts, or -30 to 0 Volts can be used if only a single power supply is available.

Applications

Figure 3 shows a typical connection diagram of the MT8972 and MH89726/728. RX_{OUT} and TX_{IN} of the LEC are connected to L_{OUT} and L_{IN} of the DNIC respectively. Pins 5, 6 and 7 are the power supply pins, with the voltages being supplied as indicated in the table. An external resistor, R_{EXT}, may be used to increase the gain of the transmitter. Without R_{EXT}, TX_{GAIN} and TX_{OUT} are shorted together resulting in a transmit power level of +10 dBm.

R_{LL}, R_L, and C_L comprise the termination network and are used to match the characteristic impedance of the transmission line. This provides the 4 wire to 2 wire hybrid conversion necessary for twisted pair transmission.

Figure 4 shows a typical application of the LEC. On short loops, jumpers (or switches) could be used to remove the LEC from the circuit. For longer loops, the jumpers could be changed to include the LEC in the signal path.

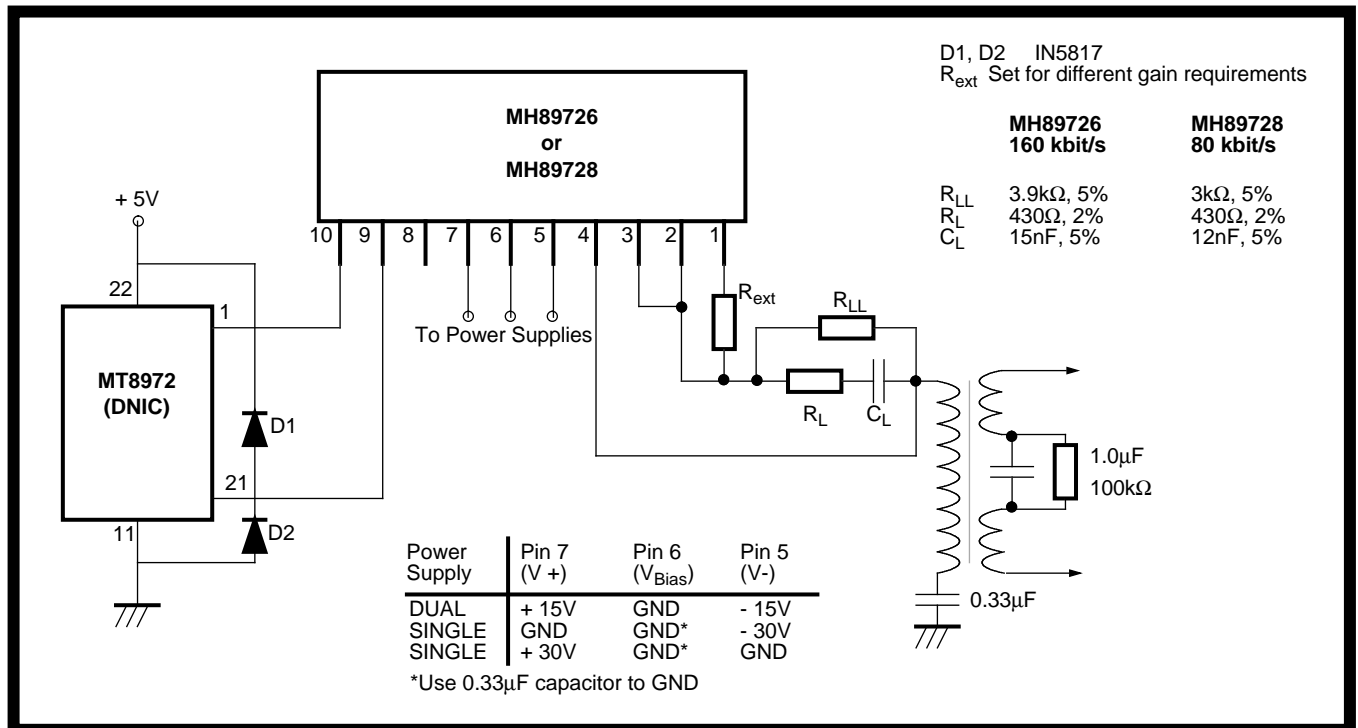

Figure 3 - Typical Connection Diagram for MT8972 and MH89726/728

MH89726 (160 kbit/s)		
CONFIGURATION \ CABLE	24 AWG (8.0 dB/km at 120 kHz)	26 AWG (11.5 dB/km at 120 kHz)
DNIC to DNIC	0.0 to 4.1 km	0.0 to 3.0 km
DNIC with LEC to DNIC with LEC	0.65 to 5.1 km	0.5 to 3.6 km

Table 1 - Typical Transmission Performance at 160 kbit/s

MH89728 (80 kbit/s)		
CONFIGURATION \ CABLE	24 AWG (6.9 dB/km at 60 kHz (Note 1))	26 AWG (10.0 dB/km at 60 kHz)
DNIC to DNIC	0.0 to 5.2 km	0.0 to 3.4 km
DNIC with LEC to DNIC and LEC	0.9 to 6.5 km	0.65 to 4.1 km

Table 2 - Typical Transmission Performance at 80 kbit/s

Note 1: The attenuation of the cable as specified by Bell System Technical Reference PUB 62411.

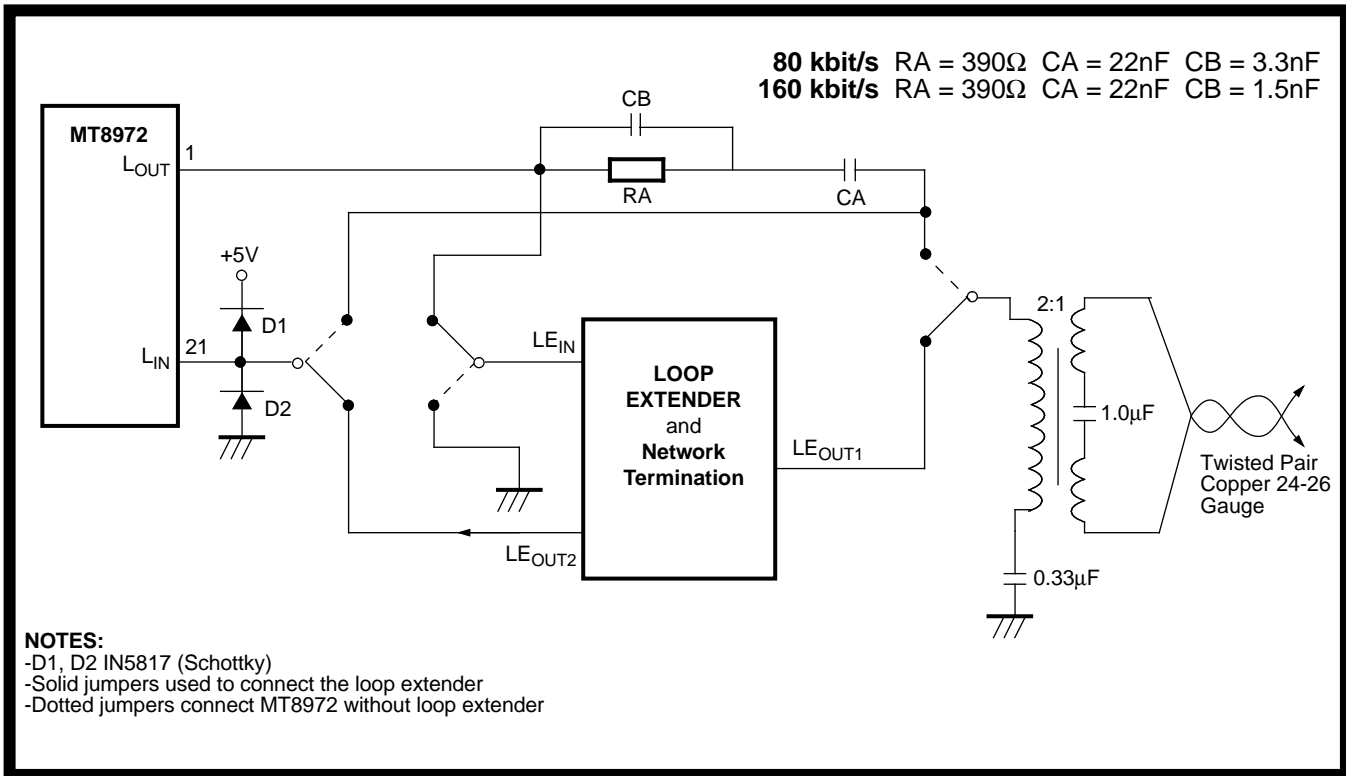

Figure 4 - Typical Application of the Loop Extender

Recommended Operating Conditions

	Characteristics	Sym	Min	Typ	Max	Units	Test Conditions
1	+ 15 V Supply	V_{DD}	13.5	15.0	16.5	V	Note 1
2	- 15 V Supply	V_{SS}	-16.5	-15.0	-13.5	V	Note 2
3	Standby Current	I_S		3.0		mA	

Note 1: A single voltage supply of $+30V \pm 10\%$ can be used on V_{DD} with V_{Bias} grounded through a $0.33 \mu F$ capacitor and V_{SS} grounded.

Note 2: A single voltage supply of $-30V \pm 10\%$ can be used on V_{SS} with V_{Bias} grounded through a $0.33 \mu F$ capacitor and V_{DD} grounded.

A.C. Electrical Characteristics

	Characteristics	Sym	Min	Typ	Max	Units	Test Conditions
1	Active Current	I_A		7.0		mA	@ 60 kHz for 80 kbit/s @ 120 kHz for 160 kbit/s
2	TX Gain	A_{TX}		9.0		dB	@ 60 kHz for 80 kbit/s @ 120 kHz for 160 kbit/s
3	TX Phase Angle	Φ_{TX}		-170.0		°	@ 60 kHz for 80 kbit/s @ 120 kHz for 160 kbit/s
4	RX Gain	A_{RX}		0.0		dB	@ 60 kHz for 80 kbit/s @ 120 kHz for 160 kbit/s
5	RX Phase Angle	Φ_{RX}		12.0		°	@ 60 kHz for 80 kbit/s @ 120 kHz for 160 kbit/s
6	Line Power			10.0		dBm	With 2:1 transformer

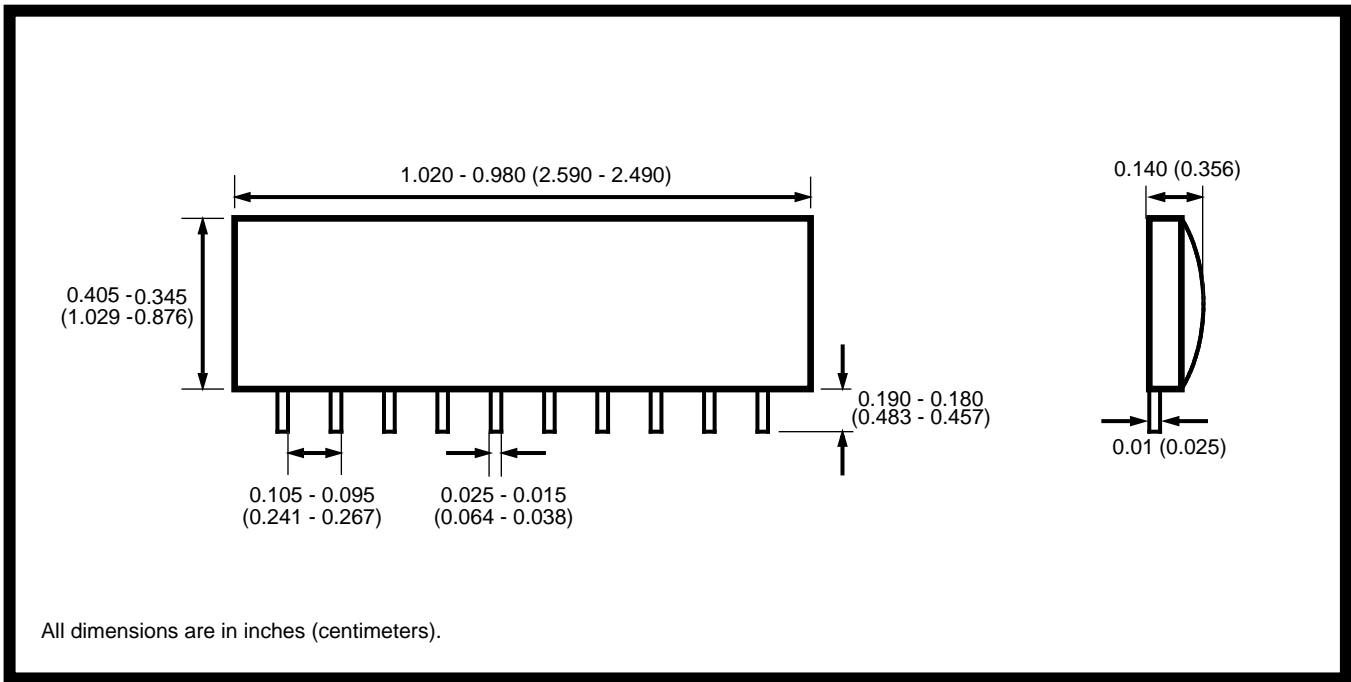

Figure 4 - Mechanical Data